

Glassboy 500 [500kg]

With a lifting capacity of up to 500kg and a maximum hook height of 2.7m, the Glassboy 500 is a compact and lightweight crane that can be used between floors for raising loads from the ground with its optional electric hoist.

The Glassboy 500 can assist with a broad range of lifting applications. It is ideal for shop-front glazing and fitting below overhangs when used in conjunction with below-the-hook devices such as GGR Group's range of vacuum lifters.



Technical Specifications	Capacity	Arm Extension
Position 1	500kg	900mm
Position 2	420kg	1020mm
Position 3	370kg	1140mm
Position 4	300kg	1260mm
Weight (without counterweights)	134kg	
Weight (with counterweights)	706kg	
Counterweights	26	

Key Features

- Capacity: 500kg
- Maximum hook height of 2.7m
- Hydraulic lifting arm
- Optional electric hoist for raising loads from the ground up
- Lockable rear wheels
- Easily assembles and disassembles for transport by van
- Vacuum lifter hired/sold separately
- Weight: 706kg (with counterweights)



Technical Data (mm)

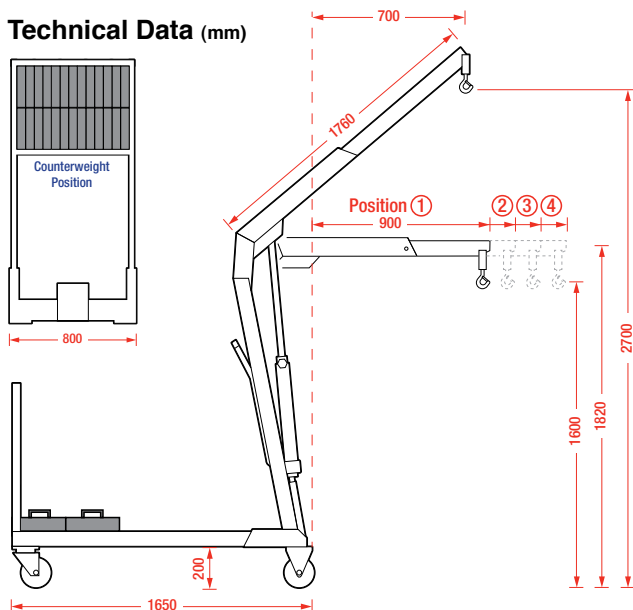

Note: Weights must be secured before lifting

