

232 SINGLE WIDTH TOWER 3T - THROUGH THE TRAPDOOR METHOD

TUV CERTIFIED QUALITY SYSTEM
TO ISO 9001:2015

GS PRODUCT APPROVAL TO
BS.EN.1004-1 3 8/12 XXXD H1

INSTRUCTION MANUAL
EN 1004-2-en

TOWER MAX SAFE WORKING LOAD 750KG | PLATFORM MAX SAFE WORKING LOAD 250KG

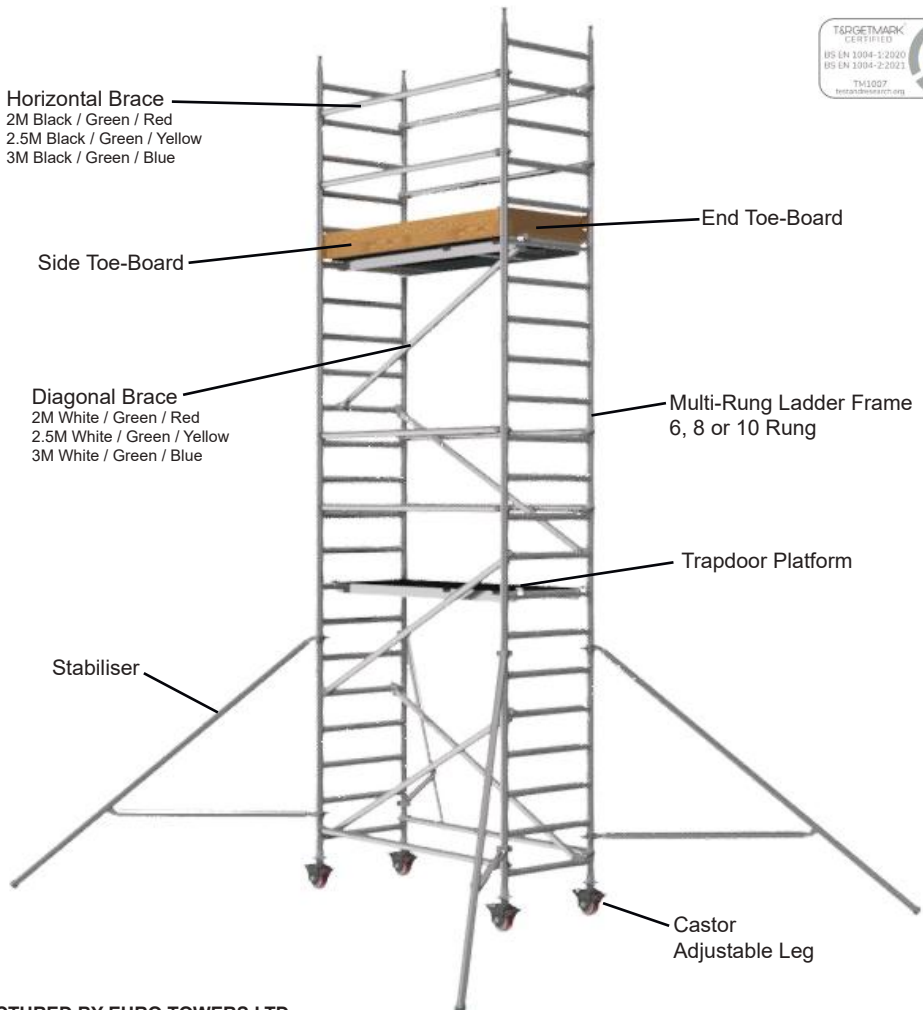

MANUFACTURED BY EURO TOWERS LTD

SAFETY DO'S AND DONT'S

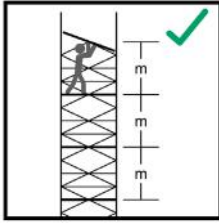

Maximum distance between platforms shall not exceed 2.25m except the distance to the first platform max 3.40m

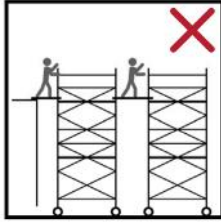

Do not bridge between towers or other structures Please contact Euro Towers for information on the correct equipment for Bridging Towers

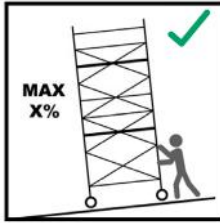

Maximum inclination for movement. Note the maximum angle allowed is 1%.

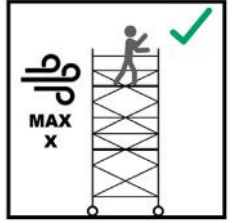

Do not build, dismantle or attempt to work on an access tower if the wind speed exceeds 17MPH

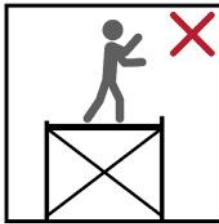

Do not stand on an unguarded platform

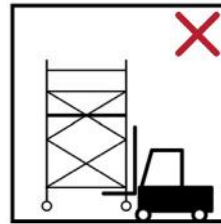

Do not lift the tower with mechanical equipment

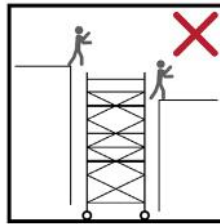

Do not use the tower for access and egress to other structures

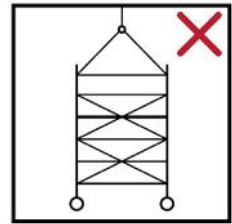

Do not suspend the tower

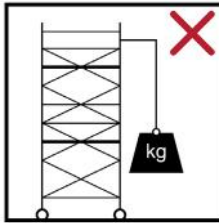

Do not lift heavy objects from the tower

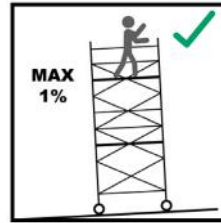

Maximum inclination for working. Note the maximum angle allowed is defined by the manufacturer.

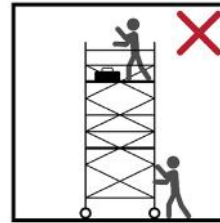

Do not move the tower with people or materials on it



Do not use ladders, boxes or other objects to gain extra height

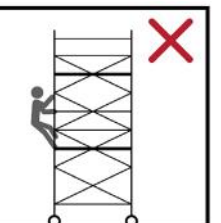
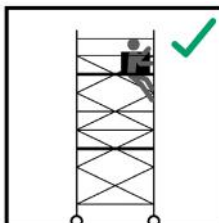

Do not climb the outside of the tower

GENERAL SAFETY RULES

Mobile access towers are for the purpose of working at height safely.

Before You Start

1. Familiarise yourself with these instructions paying attention to these safety notes before you use the equipment supplied.
Towers may only be assembled and dismantled by a COMPETENT person familiar with these instructions.
2. User training courses cannot be a substitute for instruction manuals but only complement them. Although training is not a specific legal requirement, it is one of the most recognised methods of proving competency.
3. This product shall only be used according to the instruction manual.
4. Only original Euro Towers components specified in this manual shall be used.
5. It is recommended that this user manual be used in conjunction with a suitable risk assessment and method statement relative to the project.
6. This instruction manual shall be available on the location of use of the mobile access and working tower.
7. This mobile access and working tower shall only be used according to this manual without any modification.
8. Mobile access and working towers shall only be used in accordance with national regulations
9. You will require the following PPE to help avoid personal injury, Hard Hat, Safety Gloves, Safety Shoes and Hi Vis vest or jacket
10. Tools required for safe erection of a tower are: Spirit level.
11. As part of your risk assessment do not begin to erect, move or dismantle your tower in excessive weather conditions including heavy rain, sleet/snow or weather that can affect your anti slip surfaces. Also avoid working in extreme heat and high winds.
12. Ensure you selected the correct platform height tower in relation to the desired working height (usually 2m) to avoid over reaching and other unsafe practices.
13. Inspect all individual components before use to ensure quantity, compatibility, any damages and all parts function correctly. Damaged or incorrect components shall NOT be used.
14. Check the quantity of components supplied corresponds correctly to the kitting list of the tower height you are planning to build. Do not start assembly if you do not have the correct number of components. Do not use any tower that has missing or damaged parts or has not been properly assembled.
15. Erect an exclusion zone and place warning signs if applicable to your location of work.
16. It is recommended that a minimum of two person erect, alter and dismantle a Tower but during the risk assessment additional person(s) may be required to perform the task safely.

Inspection, Care, Maintenance and transport

17. Regularly inspect the individual components to ensure that they are not damaged and function properly. Damaged components shall be isolated, tagged and removed from use. They should be replaced and sent for repair or scrap.
18. Inspect all tubes on frames, stabilisers and braces for dents, cuts and holes, damaged equipment should be isolated, tagged and removed from use. Check all joints for cracked welds and that they are secure.
19. Inspect Brace Hooks, check the clicker is functioning correctly and the hook is not distorted from abuse. Check the brace is not bent out of shape.
20. Inspect Platform for damage to the decking and fixings and that (if fitted) the trapdoor opens and closes freely and the hinge is secure. Check the aluminium framework for damage and for cracked welds that may be damaged due to overloading. Check the hooks are not distorted from abuse and the wind lock clips are attached and functioning properly.
21. Inspect Stabiliser couplers tighten and can be loosened freely. Ensure rubber foot is securely fitted and not worn out. Check for adjusting pins on telescopic stabilisers are fitted and secured
22. Inspect castors, checking that the wheel turns and spins freely, that the brakes engage and stops the castor from spinning. Ensure the castor has no flat spots and has a suitable SWL and is correctly marked.
23. Inspect the adjustable leg threads are clear of burrs and the nut runs freely up and down the thread. Check the nut housing for abuse or missing nodules.
24. Light oil or lubricating spray may be used to free up jammed, clickers, castors, adjustable leg nuts, stabiliser couplers, trap door hinges and latches.
25. Do not put excessive loads on the components during storage.
26. When transporting the components do not use excessive strapping forces when securing the load, this may distort and damage components if not done with care.
27. Check ground conditions are suitable for erecting and moving the tower and the ground can take the loads imposed by the tower including weight of equipment and persons. Do not assemble tower on unstable ground such as drain, manhole covers, compacted fill or any other hazards highlighted during the risk assessment
28. Ensure the level and slope of the area where the tower is to be erected, moved and dismantled is within the levelling height of the adjustable legs.
29. Check for obstructions that could prevent safe erection, moving and dismantling of the tower.
30. Ensure the Tower is level. Castor wheels should always remain LOCKED unless moving the Tower. Adjustable legs are used for levelling the Tower. NEVER use to gain additional height. Extra height is gained by using additional compatible components. Other items such as ladders, steps or boxes should never be used to gain additional height.
31. Check for overhead hazards such as power lines. Do not assemble a tower near uninsulated, live or energised electrical machinery or circuits, or near machinery or plant that is in operation.

32. All components should be passed up or down by hand where possible, where this is not possible use a suitable material for lifting (e.g. Heavy corded rope) and sufficient knot ties (e.g. hitch knot or timber hitch) DO NOT use mechanical hoists.
33. Towers MUST always be climbed from the inside for access and egress using the Integrated ladders or designated rungs. NEVER climb the outside of a Tower.
34. Do not lean ladders against a tower or climb the outside. Climb the ladder from the inside as per the supplied access system and use the trapdoor for access and egress
35. Never climb on Diagonal or Horizontal braces. Never jump on to or off platforms
36. Working is only permitted on a platform with a complete side protection including guardrails and toe boards
37. After assembly or alteration, the following minimum information shall be displayed on the tower:
 - a. The name and contact details of the person responsible
 - b. If the tower is ready for application or not
 - c. The load class and the uniformly distributed load
 - d. If the mobile access and working tower is intended for indoor use only; and
 - e. The date of assembly

Safe Use & Loadings

38. Before use, check that all components listed in the kit list have been used in the Tower in the correct position. Then repeat all checks if the tower has been moved, modified, left unattended or the environment changes.
39. Care should be taken when using Power Tools or Jet washing or anything specific to your job that could imply side loads and cause the tower to overturn. Maximum permitted side load must not exceed 30kg (300N)
40. When lifting components or materials keep within the base of the Tower. Ensure the total weight of the User(s) any debris or materials being lifted does not exceed the Safe Working Load (SWL) of an individual platform (250kg) or the overall structure (750kg) Loads must be uniformly distributed on the working platform and not block trapdoors.
41. Mobile access and working towers designed in accordance with EN1004-1 are not anchor points for personal fall arrest equipment.
42. Work should only be completed from one Working Platform at any time complete with Guardrails and Toe-boards to prevent persons and materials falling from the tower. Work should not be attempted from any other part of the tower including stairs or braces.
43. The maximum number of person(s) permitted on the working platform at any time should not exceed the SWL (250kg). This should include any tools and or materials
44. You should never stand on an unprotected platform (guardrails must be in place)
45. Consider measures to avoid unauthorised access or tampering when the tower is left unattended.

Stability & Moving

48. Ensure the Tower is always level and the adjustable legs are engaged. Check that you have taken all necessary precautions to prevent the Tower being moved or rolling away. Always apply ALL castor brakes or use base plates for static towers or inclined surfaces.
49. Ensure that the scaffold tower is within the maximum platform height as stated and that the appropriate stabilisers are fitted to suit. *refer to kitting list
50. A scaffold tower should not be used or moved in wind speeds stronger than 17mph (7.7meters per second) (Beaufort force 4). Wind speeds in excess of this consider tying the tower to a rigid structure or dismantling before it is exposed to the strong winds.
51. Beware of the potential wind factors where there is a possibility for the tunnelling effect of open-ended buildings, unclad buildings and at the corners of buildings
52. NEVER fit sheets or cladding to a Tower. Such items can act as a sail and impose extreme horizontal loads onto a tower causing it to overturn.
53. When moving a tower plan the route removing any obstructions, ensuring the ground can take the weight of the tower, beware of soft and uneven ground. Pay attention for overhead hazards. Ensure that all materials and persons are removed from the Tower. If there are any doubts about the route, then dismantle and erect in new location.
54. Towers should only be moved manually by pushing at the base of the tower at a usual walking speed on a slope no greater than 1%. The Tower height should be reduced to 4m if all 4 stabilisers are in place and 2m if less than 4 stabilisers are in place. Stabilisers are raised approximately 25mm clear off the ground and then castors are unlocked before moving.
55. When the Tower is repositioned reapply the brakes on castor wheels ensuring the Tower is still complete and correct. The tower shall be levelled using the adjustable legs for both horizontal and vertical alignment. The stabilisers can then be lowered making firm contact with the ground.
56. Mobile access and working towers in accordance to EN1004-1 should NEVER be lifted or suspended by a crane or moved by mechanical means
57. Mobile access and working towers in accordance to EN1004-1 are not designed to be used as a means to enter or exit other structures, e.g. as a stair tower.
58. Mobile access and working towers in accordance to EN1004-1 are not designed to be used as a means of edge protection

Further information on inspection and maintenance can be found on Euro Towers inspection posters. For further safety information or downloading instructions call Euro Towers or visit our website. www.eurotowers.co.uk

3T 232 MULTI RUNG SCAFFOLD TOWER SINGLE WIDTH KIT LIST

Available in three lengths: 2m, 2.5m or 3m

| | | | | | | |
|--------------------------------|-------------|-------------|------------------------|-------------|-------------|--------------|
| WORK HEIGHT | 3.3m | 3.8m | 4.3m | 4.7m | 5.2m | 5.7m |
| OVERALL TOWER HEIGHT | 2.6m | 3.1m | 3.6m | 4.0m | 4.5m | 5.0m |
| PLATFORM HEIGHT | 1.3m | 1.8m | 2.3m | 2.7m | 3.2m | 3.7m |
| PARTS LIST | | | | | | |
| CASTOR | 4 | 4 | 4 | 4 | 4 | 4 |
| ADJUSTABLE LEG | 4 | 4 | 4 | 4 | 4 | 4 |
| 3/6 RUNG FRAME | | 4 | 2 | | | 4 |
| 4/8 RUNG FRAME | | | 2 | 4 | 2 | 2 |
| 5/10 RUNG FRAME | 2 | | | | 2 | |
| DIAGONAL BRACE | 2 | 2 | 3 | 3 | 4 | 4 |
| HORIZONTAL BRACE | 6 | 6 | 6 | 10 | 10 | 10 |
| TRAPDOOR PLATFORM | 1 | 1 | 2 | 2 | 2 | 2 |
| STANDARD STABILIZER | | 4 | 4 | 4 | 4 | 4 |
| TELESCOPIC STABILIZER | | | | | | |
| TOEBOARD ASSEMBLY | 1 | 1 | 1 | 1 | 1 | 1 |
| TOWER WEIGHT (Kgs) | | | | | | |
| 2m WEIGHT | 80 | 94 | 114 | 125 | 130 | 136 |
| 2.5m WEIGHT | 82 | 104 | 127 | 139 | 145 | 151 |
| 3m WEIGHT | 88 | 110 | 138 | 152 | 158 | 164 |
| COMPONENT WEIGHT (Kgs) | | | | | | |
| 4 Rung Single Width 232 Frame | FKS2/4 | 3.69 | Single Width Guardrail | FKSG | | 3.09 |
| 6 Rung Single Width 232 Frame | FKS3/6 | 5.08 | 2M Plain Platform | PKP1 | | 13.22 |
| 8 Rung Single Width 232 Frame | FKS4/8 | 6.47 | 2.5M Plain Platform | PKP2 | | 16.88 |
| 10 Rung Single Width 232 Frame | FKS5/10 | 7.86 | 3M Plain Platform | PKP3 | | 20.29 |
| 2m Toe-board Length | TKL1 | 2.29 | 2M Trapdoor Platform | PKT1 | | 13.48 |
| 2.5m Toe-board Length | TKL2 | 3.68 | 2.5M Trapdoor Platform | PKT2 | | 17.38 |
| 3m Toe-board Length | TKL3 | 3.85 | 3M Trapdoor platform | PKT3 | | 21.83 |
| Single Width Toe-board | TKSW | 0.98 | | | | |

MOVING A TOWER

Remove people and materials from the tower, and lower the tower to 4m if all 4 stabilisers are in place. If not then reduce tower height to 2m. Adjust and raise the stabilizers 25mm from the ground, ensure the couplers are tight, and push from at or near the base by manual effort only, never use mechanical means. Recheck level and reposition stabilizers before use.

ALTERNATIVE FRAMES CONFIGURATION: For example where 2 x 8 rung frames are stated making the tower 16 rungs in total, these can be replaced by 1 x 10 rung and 1 x 6 rung, also making 16 rungs in total.

PPE REQUIRED: Hard Hat, Safety Gloves, Safety Boots/Shoes, Hi-Viz Vest/Jacket

TOOLS REQUIRED: Spirit Level

| | | | | | | | | |
|-----------------------|------|------|-----------------------|------|------|------|------|------|
| 6.2m | 6.6m | 7.0m | 7.5m | 8.0m | 8.5m | 8.9m | 9.4m | 9.8m |
| 5.5m | 5.9m | 6.3m | 6.8m | 7.3m | 7.8m | 8.2m | 8.7m | 9.1m |
| 4.2m | 4.6m | 5.0m | 5.5m | 6.0m | 6.5m | 6.9m | 7.4m | 7.8m |
| | | | | | | | | |
| 4 | 4 | 4 | 4 | 4 | 4 | 4 | 4 | 4 |
| 4 | 4 | 4 | 4 | 4 | 4 | 4 | 4 | 4 |
| 2 | 2 | | 4 | 4 | 2 | | | 4 |
| 4 | 2 | 4 | 4 | 2 | 4 | 6 | 4 | 4 |
| | 2 | 2 | | 2 | 2 | 2 | 4 | 2 |
| 5 | 5 | 5 | 6 | 6 | 7 | 7 | 8 | 8 |
| 10 | 10 | 14 | 14 | 14 | 14 | 14 | 18 | 18 |
| 2 | 2 | 3 | 3 | 3 | 3 | 3 | 4 | 4 |
| 4 | 4 | | | | | | | |
| | | 4 | 4 | 4 | 4 | 4 | 4 | 4 |
| 1 | 1 | 1 | 1 | 1 | 1 | 1 | 1 | 1 |
| | | | | | | | | |
| 142 | 145 | 157 | 163 | 190 | 193 | 198 | 204 | 210 |
| 157 | 160 | 172 | 178 | 210 | 214 | 219 | 225 | 231 |
| 170 | 174 | 186 | 192 | 229 | 234 | 240 | 245 | 252 |
| | | | | | | | | |
| 2M Horizontal Brace | BKH1 | 1.93 | 5" Castor | | | K5CR | 3.23 | |
| 2.5M Horizontal Brace | BKH2 | 2.24 | 6" Castor | | | K6CR | 3.65 | |
| 3M Horizontal Brace | BKH3 | 2.55 | 8" Castor | | | K8CR | 4.34 | |
| 2M Diagonal Brace | BKD1 | 2.06 | Adjustable Leg | | | KALA | 0.98 | |
| 2.5M Diagonal Brace | BKD2 | 2.35 | Standard Stabilizer | | | SKS1 | 4.02 | |
| 3M Diagonal Brace | BKD3 | 2.65 | Large Stabilizer | | | SKL2 | 7.84 | |
| Swivel Base Plate | KSBP | 1.03 | Telescopic Stabilizer | | | Y250 | 5.66 | |

STABILIZERS

Stabilizers increase the EFFECTIVE BASE dimensions and improve the STABILITY of the tower. Position the stabilizers symmetrically to obtain the MAXIMUM BASE DIMENSION.

| PLATFORM HEIGHTS | MAXIMUM HEIGHT | STABILIZER TYPE |
|------------------|----------------|-----------------|
| 1.2m | 2.2m | NONE |
| 2.7m | 5.2m | STANDARD |
| 5.7m | 12.2m | TELESCOPIC |

Stabilizers must be used for all platform heights of 2.2m and above at all times.

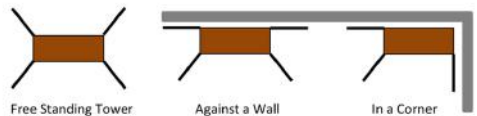

TOE-BOARDS

Notched toe-board assembly is made up of 2 lengths and 2 ends.

SINGLE WIDTH 232 FRAME INSTRUCTION MANUAL FOR ERECTION, ALTERING & DISMANTLING

The tower requires a minimum of 2 people for assembly; do not attempt to assemble a tower by yourself
Builds with 3 rung & 4 rung base set ups have platforms repositioned.
Builds with 2x3 rung base set ups have the platform positioned on the 4th rung.
*When a diagonal brace runs past a platform, the brace should be in position 1.

6/6 Rung Base Setups SW

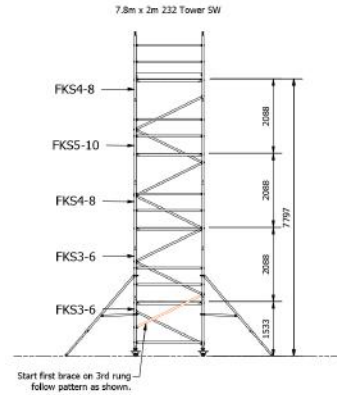
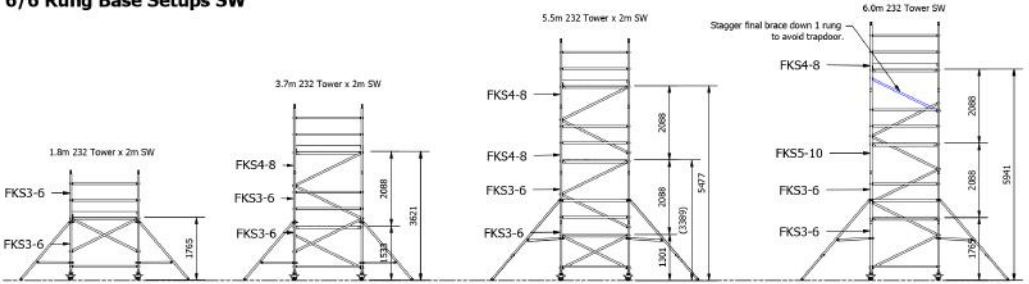

8/8 Rung Base Setups SW

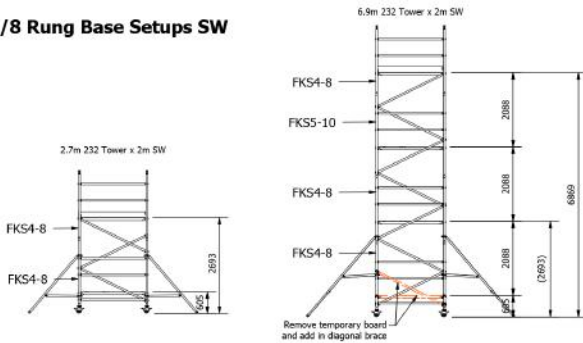

8/10 Rung Base Setups SW

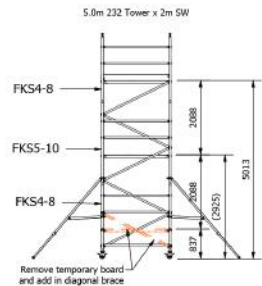

6/8 Rung Base Setups SW

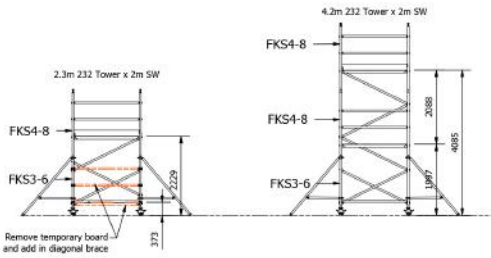

8 Rung Base Setups SW

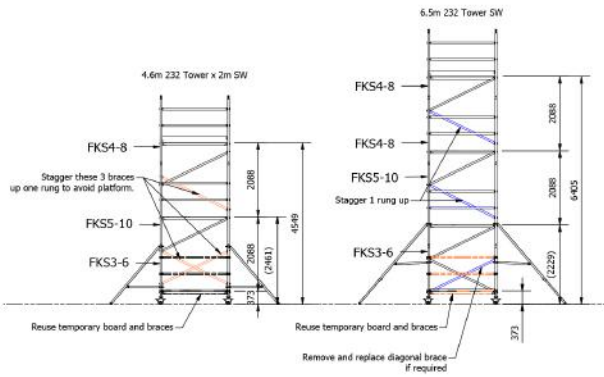

10 Rung Base Setups SW

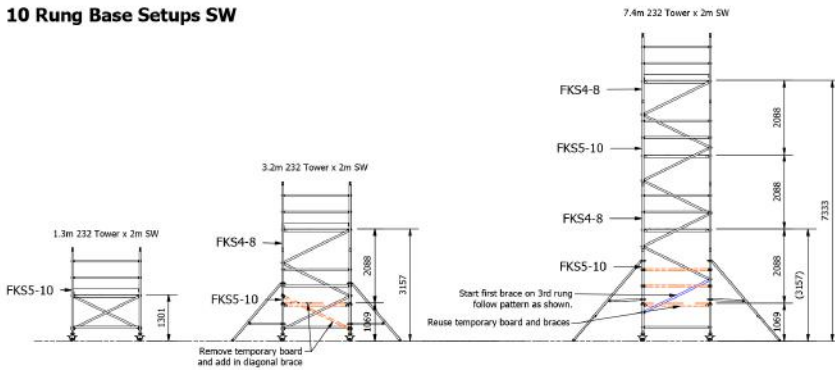

ASSEMBLY STEPS

How to fit a stabiliser coupler



How to fit a brace



How to remove a brace



How to fit notched Toe-Boards

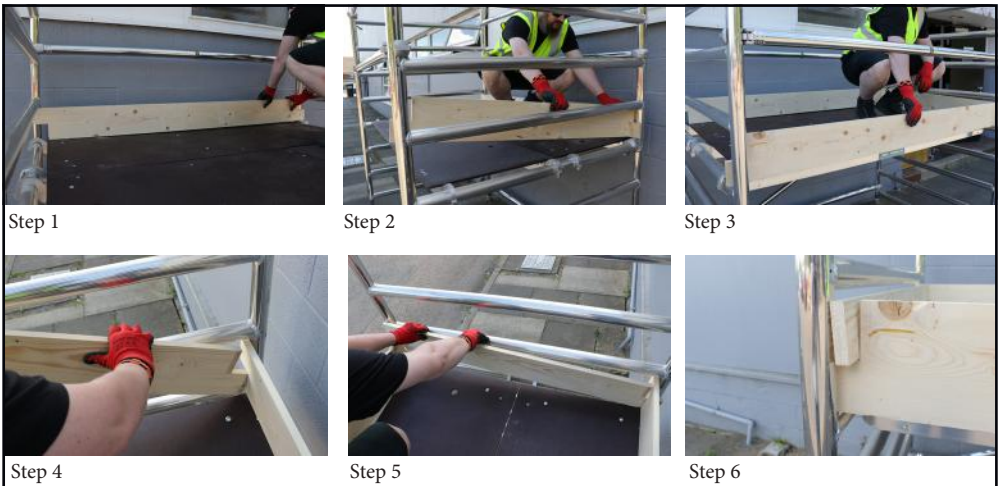



1. Insert castor wheels into adjustable legs



2. Insert 2 adjustable legs and castor wheels into each base frame



3. Lock Brakes and allow 3" thread from bottom of castor for levelling



4. Fit 2 horizontal braces to the vertical member of the frames above first rung. Horizontal braces fit on from the inside of the tower facing outwards



5. Fit 1 plain platform on the appropriate rung. (See base build for desired platform height). Level your tower by the adjustable legs using a spirit level as a guide.

The scaffold must be vertical in both planes within an inclination of 1%

NEVER STAND ON AN UNPROTECTED PLATFORM



6. Add further frames.



7. After adding frames always remember to engage interlock clips



8. Fit 2 more diagonal braces to continue in a regular pattern on the 3rd rung leaving room for your horizontal braces to fit on the upright.



9. Fit 4 horizontal braces directly above platform to create your collective protection. Hooks facing outwards on frame uprights.



10. Fit 4 stabilisers at earliest opportunity keeping lower arm as horizontal as possible.



11. From the temporary platform, fit 1 diagonal brace to 3rd rung down and fit trapdoor platform over the hook. Offset platform to oneside and run the diagonal brace away from the trapdoor.



12. Remove temporary platform and the 4 horizontal braces. Relocate the 2 diagonal braces from 3rd to 1st rung.



13. From a seated position using the through the trapdoor (3T) method. Fit 4 horizontal braces, hooks facing outwards to the frame upright.



14. Continue erecting the tower fitting the frames and diagonal braces as illustrated using all components. Platforms inserted every 2m complete with handrails. Braces run in a continuous pattern on opposite sides.



15. For your working platform fit trapdoor on the 6th rung down from the top of the tower.



16. From a seated position, using the 3T method, fit 4 horizontal braces above the appropriate rungs to the frame vertices, hooks facing out.



17. Fit toe-boards in correct position

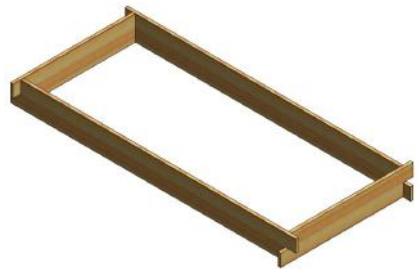



Unclip 4 x Horizontal braces from the far end of the trapdoor platform.



From a seated position remove 4 x guardrails making sure you never stand on an unprotected platform.



From a seated position descend down the tower to the next platform or ground. Ensure you always have collective protection around you when standing on any platform.